

Scales

"Advanced technological systems for chemical and food industry"

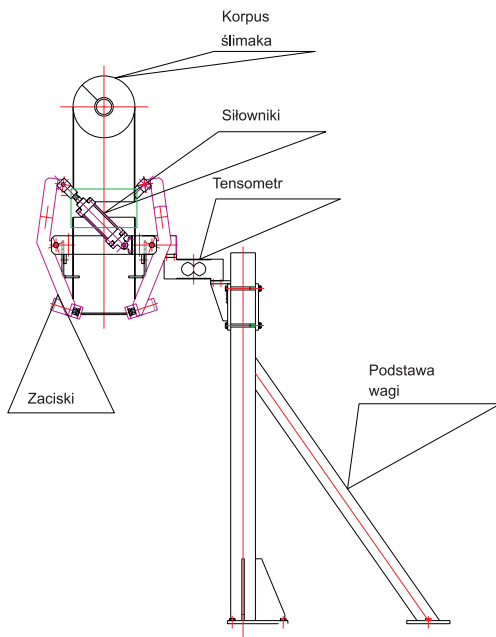

Application:

The scales is used for weighing all sorts of loose materials batched in open sacks.

Advantages

Wide scope of batching. Simple construction. Safety (double system of limit switchers).

Full automation of the process of weighing.

The head of the scales can be set at any height.

Description

The scales is most often used together with band and screw conveyors. This enables the charging of the material directly onto the head of the scales. The support of the scales is welded of 80x80 metal sections. The head is equipped with two pneumatic motor operators which press down the sack. The entire device rests on a tensometric converter which is fixed to the support of the scales. At the top, there is a flexible sleeve which connects the scales with the conveyor.

Technical data:

The scope of weighing is dependent on the type of a tensometric converter (on the basis of the information provided by the customer).

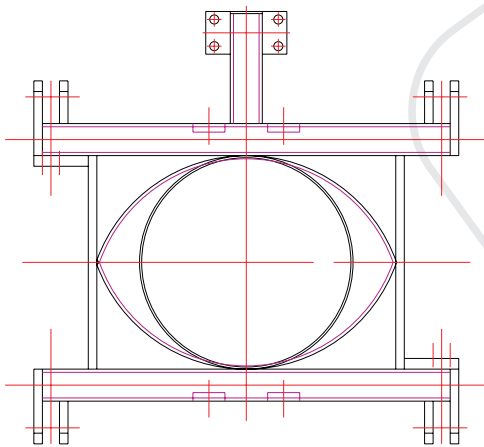

Offered devices can differ from presented on the photos.



www.mysak.pl

Contact:

tel. (+48 61) 81 01 627
fax (+48 61) 84 29 634

Adress:

Mysak Group Sp. z o.o. sp.k.
Ul. Haber-Włyńskiego 7
60-408 Poznań, Poland